

TECHNOLOGY AND SAFETY

For those who choose to **relish** the art of cooking



Faber presents a range of Built-in Hobs in 304 Stainless steel (Satin & Antiscratch finish) and Glass hobs, to give a touch of class to your modern kitchen.

Faber hobs are fitted with **ITALIAN BURNERS** used by the leading brands world wide.

All hobs are fitted with a **TRIPLE RING** Burner ideally suited for making chapatis.

GL series hobs are fitted with a Gas cut-off **FLAME FAILURE DEVICE (FFD)** which cuts off the gas supply incase the flame goes off.

Faber presents a range of Cooktops in 304 Stainless steel and Glass Cooktops, to give a touch of class to your modern kitchen.

Faber Cooktops are fitted with Triple flame **“INDIAN BRASS BURNERS”** with Lifetime warranty.

AI (Auto ignition) Cooktops are fitted with a Auto ignition switch for hassle free cooking.

Steel cooktops with **ISI** certification



Triple Ring Burner: This is a special purpose Burner provided in select models of Faber Cooking ranges. This Triple Ring Burner is specially provided to produce three concentric flame rings ideal for work cooking and preparing chapatis as it generates uniform heat at the centre and around the base of large pans or tavas. All burners are ISO 9001 certified and their performance in terms of efficiency and emission of carbon monoxide is exceptional.



- Robust Brass Burners with lifetime warranty and 100% safety
- ISI Certified Product (Steel Cooktops)
- User friendly flexible Nozzle with 360 degree swivel
- Higher thermal efficiency and lower gas consumption
- Large pan support, ideal for Indian cooking
- 68.5% efficiency*



Black Glass with SS Plates



Built-in Glass Hob GB 50 SSP



CRYSTAL 40 CT AI

BUILT-IN GAS HOBS- EUROPEAN SATIN FINISH

BUILT-IN GAS HOBS- GLASS & STEEL (FUSION SERIES)

MH 40 TR



- 4 Burners
- Width - 60cm
- Ignition - Auto Electric
- 1 Big Triple Ring Burner
- Finish - Stainless Steel
- Granite cut : 565 X 475 X 50

Fusion 372 SSP



- 3 Burners
- Width - 72cm
- Ignition - Auto Electric
- 2 Mini Triple Ring Burner
- Finish - Black Glass with SS Plates
- Granite cut : 695 x 485 x 50

FH 40 AMD



- 4 Burners
- Width - 60cm
- Ignition - Auto Electric
- 1 Mini Triple Ring Burner
- Finish - Stainless Steel
- Granite cut : 565 X 475 X 50

Fusion 465 SSP



- 4 Burners
- Width - 65cm
- Ignition - Auto Electric
- 1 Mini Triple Ring Burner
- Finish - Black Glass with SS Plates
- Granite cut : 625 x 475 x 50

FH 650 MT



- 4 Burners
- Width - 65cm
- Ignition - Auto Electric
- 1 Mini Triple Ring Burner
- Finish - Stainless Steel
- Granite cut : 595 X 475 X 50

Fusion 472 SSP



- 4 Burners
- Width - 72cm
- Ignition - Auto Electric
- 2 Mini Triple Ring Burner
- Finish - Black Glass with SS Plates
- Granite cut : 695 x 485 x 50

Grids suitable for round bottom vessels

• Granite cut in mm (LxWxH)

BUILT-IN GAS HOBS - GLASS SERIES

BUILT-IN GAS HOBS - GLASS & SQUARE PLATE SERIES

GL 30 AD* / GB 30 MT

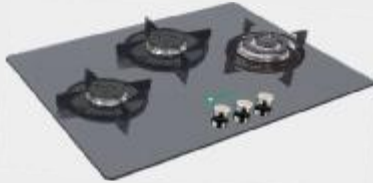

- 3 Burners
- Width - 72cm
- Ignition - Auto Electric
- 2 Mini Triple Ring Burner (GL 30 AD)
- 1 Mini Triple Ring Burner (GB 30 AD)
- Granite cut : 575 x 480 x 50

GB 30 SSP



- 3 Burners
- Width - 72cm
- Ignition - Auto Electric
- 1 Mini Triple Ring Burner
- Finish - Black glass with SS plates
- Granite cut : 575 x 480 x 50

GL 40 AD* / GB 40 MT



- 4 Burners
- Width - 72cm
- Ignition - Auto Electric
- 2 Mini Triple Ring Burners
- Granite cut : 575 x 480 x 50

GB 40 SSP



- 4 Burners
- Width - 72cm
- Ignition - Auto Electric
- 2 Mini Triple Ring Burner
- Finish - Black glass with SS plates
- Granite cut : 575 x 480 x 50

GL 95 AD* / GB 95 MT



- 5 Burners
- Width - 90cm
- Ignition - Auto Electric
- 2 Mini Triple Ring Burners
- Granite cut : 795 x 485 x 50

GB 50 SSP



- 5 Burners
- Width - 72cm
- Ignition - Auto Electric
- 2 Mini Triple Ring Burner
- Finish - Black glass with SS plates
- Granite cut : 575 x 480 x 50

GB 365 SSP



- 3 Burners
- Width - 65cm
- Ignition - Auto Electric
- 1 Mini Triple Ring Burner
- Finish - Black glass with SS plates
- Granite cut : 610 x 480 x 50

GL 50 AD* / GB 50 MT



- 5 Burners
- Width - 72cm
- Ignition - Auto Electric
- 2 Mini Triple Ring Burner
- Granite cut : 575 x 480 x 50

GB 465 SSP



- 4 Burners
- Width - 65cm
- Ignition - Auto Electric
- 1 Mini Triple Ring Burner
- Finish - Black glass with SS plates
- Granite cut : 610 x 480 x 50

* GL Series Hobs are fitted with Gas cutoff Flame Failure Device (FFD)

37 • Granite cut in mm (LxWxH)

BUILT-IN GAS HOBS - MICRODECOR

BUILT-IN GAS HOBS - MICRODECOR

FH 22 AD



- 2 Burners
- Width - 30cm
- Ignition - Auto Electric
- 1 Mini Triple Ring Burner
- Finish - Microdecor Stainless Steel
- Granite cut : 485 X 280 X 50

MDR 700 MTX



- 4 Burners
- Width - 72cm
- Ignition - Auto Electric
- 1 Big & 1 Mini Triple Ring Burner
- Finish - Microdecor Stainless Steel
- Granite cut : 695 X 475 X 50

MDR 723 MTX



- 3 Burners
- Width - 72cm
- Ignition - Auto Electric
- 1 Big & 1 Mini Triple Ring Burner
- Finish - Microdecor Stainless Steel
- Granite cut : 685 X 465 X 50

MDR 724 MTX



- 4 Burners
- Width - 72cm
- Ignition - Auto Electric
- 1 Big & 1 Mini Triple Ring Burner
- Finish - Microdecor Stainless Steel
- Granite cut : 685 X 465 X 50

MDR 40 TX



- 4 Burners
- Width - 60cm
- Ignition - Auto Electric
- 1 Big Triple Ring Burner
- Finish - Microdecor Stainless Steel
- Granite cut : 545 X 465 X 50

MDR 650



- 4 Burners
- Width - 65cm
- Ignition - Auto Electric
- 1 Mini Triple Ring Burner
- Finish - Microdecor Stainless Steel
- Granite cut : 595 X 475 X 50

MDR 603 MTX



- 3 Burners
- Width - 60cm
- Ignition - Auto Electric
- 1 Big & 1 Mini Triple Ring Burner
- Finish-Microdecor Stainless Steel
- Granite cut : 575 X 475 X 50

MDR 95 MTX



- 5 Burners
- Width - 90cm
- Ignition - Auto Electric
- 1 Big & 1 Mini Triple Ring Burner
- Finish- Microdecor Stainless Steel
- Granite cut : 875 X 475 X 50

Grids suitable for round bottom vessels

COOKTOPS - STAINLESS STEEL

COOKTOPS - GLASS

Curvy 2B CT - SS



- 2 Brass Burners (1 Small and 1 Medium)
- Finish: Stainless Steel
- Enameled Grids
- Dimension (mm) - (LxWxH) 680 x 350 x 50
- One Year Warranty
- Burners with Lifetime Warranty
- ISI Certified

CRYSTAL 300 CT



- Burner: 3 Brass Burners (1 Small and 2 Medium)
- Dimension: (LxWxH) (mm) 770 x 380 x 60
- Enameled Grids
- Finish: Tempered Black Glass
- One Year Warranty
- Burners with Lifetime Warranty

Curvy 3B CT-SS



- 3 Brass Burners(1 Small and 2 Medium)
- Finish: Stainless Steel
- Enameled Grids
- Dimension (mm) - (LxWxH) 735 x 375 x 80
- One Year Warranty
- Burners with Lifetime Warranty
- ISI Certified

CRYSTAL 30 CT AI



- Burner: 3 Brass Burners (1 Small and 2 Medium)
- Dimension: (LxWxH) (mm) 770 x 380 x 60
- Enameled Grids
- Finish: Tempered Black Glass
- Battery Operated Auto Ignition
- One Year Warranty
- Burners with Lifetime Warranty

CTG 601 SS - New



- 4 Brass Burners (2 Small and 2 Medium)
- Finish: Stainless Steel
- Enameled Grids
- Dimension (mm) - (LxWxH) 600 x 500 x 55
- One Year Warranty
- Burners with Lifetime Warranty
- ISI Certified

CRYSTAL 400 CT



- Burner: 4 Brass Burners (2 Small and 2 Medium)
- Dimension: (LxWxH) (mm) 635 x 500 x 60
- Enameled Grids
- Finish: Tempered Black Glass
- One Year Warranty
- Burners with Lifetime Warranty

CRYSTAL 20 CT AI



- Burner: 2 Brass Burners (1 Small and Medium)
- Dimension: (LxWxH) (mm) 700 x 380 x 60
- Enameled Grids
- Auto Ignition
- Finish: Tempered Black Glass
- One Year Warranty
- Burners with Lifetime Warranty

CRYSTAL 40 CT AI



- Burner: 4 Brass Burners (2 Small and 2 Medium)
- Dimension: (LxWxH) (mm) 635 x 500 x 60
- Enameled Grids
- Finish: Tempered Black Glass
- Battery Operated Auto Ignition
- One Year Warranty
- Burners with Lifetime Warranty

KITCHEN APPLIANCES



BUILT-IN ELECTRIC OVENS



BUILT-IN ELECTRIC OVENS



FBIO 58L 4F

General

- Oven Capacity 58 ltr.
- 230 volts, Frequency: 50/60 Hz, Current: 13A
- Finish - Fully glass + SS 304, "B" class Energy efficiency
- Certification - GS/EMC/CE/CB/SAA
- Oven Size - W*D*H: 595*573*595
- Carcass Size - W*D*H: 560*600*568
- Net Weight 33.5, Gross Weight 35.5
- Forced cooling System, Smoke ventilation

Functions

- Temperature range 50-250°C
- 120 hours Timer
- Light
- Conventional heat
- Radiant grilling
- Bottom heat

Control panel

- Mechanical control, Turn knob

Door plate

- Door Plate - 3 layer
- Inner Door plate - full glass
- Plastic handle

Cavity

- Enameled Interiors for Easy Cleaning
- Rack support
- Bottom element - Concealed

Parameters

- Top element - 2000W, Bottom element - 1100W
- Light bulb - 25W

Accessories

- 1 Wire Shelf
- 1 Drip Tray



FBIO 56L 8F

General

- Oven Capacity 56 ltr.
- 230 volts, Frequency: 50/60 Hz, Current: 13A
- Finish - Fully glass + SS 304, "A" class Energy efficiency
- Certification - GS/EMC/CE/CB/SAA
- Oven Size - W*D*H: 595*573*595
- Carcass Size - W*D*H: 560*600*568
- Net Weight 33,5 kg, Gross Weight 35,5 kg,
- Fixation Kit Screw
- Forced cooling System, Smoke ventilation

Functions

- Temperature range 50-250°C, 9 hours Timer, Light
- Defrosting
- Convection
- Cycle grilling
- Full surface grilling
- Radiant grilling
- Conventional heat
- Bottom heat

Control panel

- LED Display, Turn knob+Buttons

Door plate

- Door Plate - 3 layer
- Inner Door plate - full glass
- Plastic handle

Cavity

- Enameled Interiors for Easy Cleaning
- Rack support, Bottom element - Concealed

Parameters

- Radiant element - 2100W, Ring element - 2200W
- Top element - 950W, Bottom element - 1100W,
- Light bulb - 25W

Accessories

- 2 Wire Shelf
- 1 Drip Tray

BUILT-IN ELECTRIC OVENS



FM 660

General

- Oven Capacity 65 ltr.
- 220-240 volts, 50/60 Hz, 230V-13A 240V-15A
- Finish - Glass + SS
- Certification - GS/EMC/CE/CB/SAA
- Oven Size - W*D*H: 594*550*595
- Carcass Size - W*D*H: 555*547*570
- Net Weight: 30kg, Gross Weight: 33kg
- Fixation Kit Screw
- Cooling System

Functions

- Temperature range 50-230°C
- Timer
- Light
- Top Bottom Heating, Bottom Heating
- Fan support top & bottom heating
- Full Grill
- Grill + Fan
- Booster

Control panel

- Mechanical control

Door plate

- Door Plate - 2 layer
- Inner Door plate - full glass and SS Handle

Cavity

- Enameled Interiors for Easy Cleaning
- Rack support, Bottom element - Concealed

Parameters

- Top element - 800 W, Bottom element - 1000W
- Grill element - 1800W
- Light bulb - 25W

Accessories

- 1 Wire Shelf and 1 Drip Tray

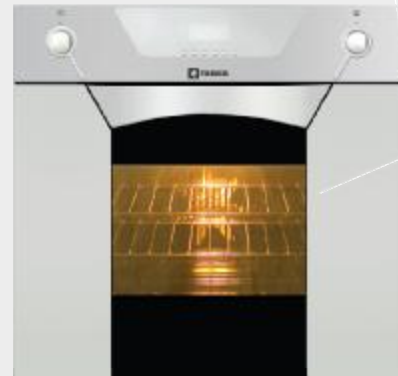

FEA 771XS

General

- Oven Capacity 52 ltr.
- 230 volts, Frequency: 50/60 Hz, Current:13A
- Finish - Glass + SS
- Certification - GS/EMC/CE/CB/SAA
- Oven Size - W*D*H: 598*476*594
- Carcass Size - W*D*H: 560*490*575
- Net Weight: 30kg, Gross Weight: 33kg
- Fixation Kit Screw
- Cooling System

Functions

- Temperature range 50-230°C, Light
- Defrost
- Upper & Lower Element
- Convection Cooking
- Lower Heating Element with Fan
- Rear Element with Fan
- Grill
- Grill with Fan

Control panel

- Digital control

Door plate

- Door Plate - 3 layer
- Inner Door plate - full glass and SS Handle

Cavity

- Enameled Interiors for Easy Cleaning
- Rack support, Bottom element - Concealed

Parameters

- Top element - 800 W, Bottom element - 1000W
- Grill element - 1800W, Rear Element - 2100 W
- Light bulb - 25W

Accessories

- 2 Wire Shelf and 1 Drip Tray

BUILT-IN ELECTRIC OVENS



FBIO 65L12F

General

- Oven Capacity 65 ltr.
- 230 volts, Frequency: 50/60 Hz, Current:13A
- Finish: Mirror Glass, "A" class Energy efficiency
- Certification - GS/EMC/CE/CB/SAA
- Oven Size - W*D*H: 595*573*595mm
- Net Weight: 33.5 Kg, Gross Weight: 35.5 Kg
- Fixation Kit Screw
- Temperature Sensor, Cooling System, Smoke ventilation
- Mirror

Functions

- Temperature range 50-250°C, 9 hour, Lamp
- Defrosting
- Bottom heat
- Conventional, Conventional+fan
- Radiant grilling
- Top heat
- Double grilling, Double grilling + fan
- Fan force
- Electronic child lock

Control panel

- LED and Digital control

Door plate

- Door Plate - 3 layer
- Inner Door plate - full glass, Aluminum Alloy Handle

Cavity

- Enameled Interiors for Easy Cleaning
- Rack support, Bottom element - Concealed

Parameters

- Top element - 950 W, Bottom element - 1100W
- Grill element - 2000W, Rear element - 2000 W
- Light bulb - 25W

Accessories

- 2 Wire Shelf and 1 Drip Tray, Rotisseries
- Telescopic runners(*1 pair), Catalytic liners(right + left sides)



MAM 82 MXS

General

- Oven Capacity 76 ltr.
- 230 volts, Frequency: 50/60 Hz, Current:13A
- Finish: SS + Glass
- Certification - GS/EMC/CE/CB/SAA
- Oven Size - W*D*H: 895*565*475mm
- Carcass Size - W*D*H: 865*560*475mm
- Net Weight: 45kg., Gross Weight : 48 kg.
- Fixation Kit Screw
- Cooling System

Functions

- Lamp
- Defrosting
- Upper & Lower Roasting
- Baking
- Convection Roast
- Convection Bake
- Convection Broil
- Broil with Rotisserie

Control panel

- Mechanical control

Door plate

- Door Plate - 3 layer
- Inner Door plate - full glass and SS Handle

Cavity

- Enameled Interiors for Easy Cleaning
- Rack support, Bottom element - Concealed

Parameters

- Top element -800W, Bottom element -1200W
- Grill element -1800W, Rear element-2500W
- Light bulb -25W

Accessories

- 1 Wire rack, 1 Drip Tray and Rotisseries

BUILT-IN MICROWAVE OVENS



BUILT-IN MICROWAVE OVENS



FBI MWO 25L

Capacity

Oven Capacity (cuft): 25L

Features

Function: Grill + Convection
 Nos. of auto prog.: 10
 Clock and Timer: LED
 Cavity Type: SUS
 Control Type: Round control and touch button knobs
 Safety: Child lock
 Accessories: Grill Rack
 Stainless Steel type: anti-finger
 Combination Cooking
 Multi Cooking
 Color: SUS
 Door Opening: Button
 Defrost

Dimensions &Weight

Net Weight: 20,9 kg.
 Gross Weight: 24.68 kg.
 Cavity Size (L*W*H mm): 300*347*228
 Unit Dimensions (L*W*H mm): 594*470*388
 Carcass Dimensions (L*W*H mm): 560*550*380

Power/Ratings

Voltage/Frequency: 230V/50Hz
 Output power: 900W
 Grill power: 1100W
 Convection Power: 2500W



FBI MWO 30L

Capacity

Oven Capacity (cuft): 30L

Features

Function: Grill + Convection
 Defrost: Speedy And Weight Defrost (meat, poultry, seafood)
 End Signal
 Microwave
 Cover: Mirror + stainless steel front, black silver housing
 Cavity: Stainless Steel
 Panel: Button and jog dial
 Display: LED
 Child safety lock
 Microwave power level :10
 Combination: 3
 Convection: 10 different cooking temperature (110°C-200°C)
 Stage Cooking: 3
 Programmable: 9 auto programs
 Timer: 95 min

Dimensions &Weight

Net Weight: 16.4 kg.
 Gross Weight: ca. 18.1kg.
 Cavity Size (L*W*H mm): 354*358*240
 Unit Dimensions (L*W*H mm): 595*495*406
 Carcass Dimensions (L*W*H mm): 560*455*370

Power/Ratings

Voltage/Frequency: 230V/50Hz
 Output Power : 900W
 Grill power: 1250W
 Convection Power: 2050W

BUILT-IN MICROWAVE OVENS



FBI MWO 32L

Capacity

Oven Capacity (cuft): 32L

Features

- Function: Grill + Convection
- Digital Control: Dial and button
- Stainless steel cavity
- Anti-finger Stainless Steel front face
- Mirror glass door
- Speedy defrost setting
- Friendly interface design
- Heat-resisted glass window
- Child safety lock
- 10 Auto cooking menus
- Express cooking
- Quick Start Function:30/60/120"

Dimensions &Weight

- Net Weight: 21.5 kg
- Gross Weight: 24.5kg
- Cavity Size (L*W*H mm): 351*358*251
- Unit Dimensions(L*W*H mm): 595*468*380
- Carcass Dimensions (L*W*H mm): 560*550*380

Power/Ratings

- Voltage/Frequency: 230V/50Hz
- Output power: 1000W
- Grill power: 1100W
- Convection Power: 2500W



FWO 300 AX C XS

Capacity

Oven Capacity (cuft): 30L

Features

- Function: Grill + Convection
- Digital Control: Dial and button
- Stainless steel cavity
- Stainless Steel front face
- Glass door
- Defrost setting
- Heat-resisted glass window
- Child safety lock
- Auto cooking menus
- Quick Start Function

Dimensions &Weight

- Net Weight: 21 kg
- Gross Weight: 24 kg
- Unit Dimensions(L*W*H mm): 595*470*460
- Carcass Dimensions (L*W*H mm): 564*560*434

Power/Ratings

- Voltage/Frequency: 230V/50Hz
- Output power: 900W
- Grill power: 1000W
- Convection Power: 2050W

BUILT-IN BARBEQUE AND DEEP FRYER



BUILT-IN BARBEQUE AND DEEP FRYER



Barbeque

- Material : Stainless Steel –European Satin Finish
- Vitro ceramic Top
- Controls : Knob Button
- On light
- Residual heat indicators
- Temperature: 100°C -180°C
- Temperature Limiter: 240°C
- Power voltage and frequency: 220 - 240 V 50 - 60 Hz
- Total power and fuse capacity: 1500 W 10A
- Product Dimensions(L *D * H): 300 * 510*30 mm
- Carcass dimensions(L *D * H): 250 * 480*30 mm
- CE Certified Products



Deep Fryer

- Material: Stainless Steel – European Satin Finish
- Auto Protection against over heating due to malfunction & low oil level usage
- On Indicator, Heating indicator, Temperature selector
- Stainless Steel Basket
- Controls: Knob Button
- Capacity: liters 3 to 4
- Power voltage: 220-24V, Frequency: 50-60 Hz
- Total Power and fuse capacity: 2300 W-16A
- Temperature: 100°C -180°C, Temperature Limiter: 240°C
- Product Dimensions (L *D * H): 300 * 510*173.5 mm
- Carcass dimensions (L *D * H): 250 * 485*28.5 mm
- CE Certified Products



- (A) Control Panel
- (B) Cooking hob
- (C) On light
- (D) Residual heat indicator

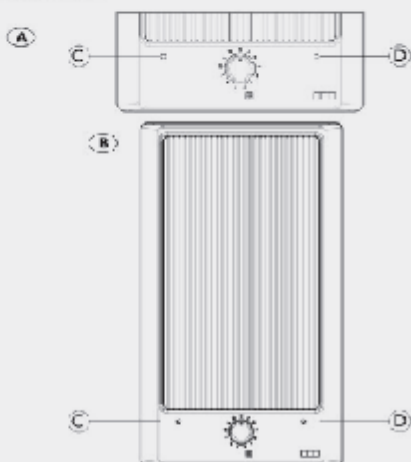

- (A) Control Panel
- (B) Fryer
- (C) On indicator
- (D) Heating indicator
- (E) Oil tank
- (F) Basket
- (G) Heating element
- (H) Temperature selector

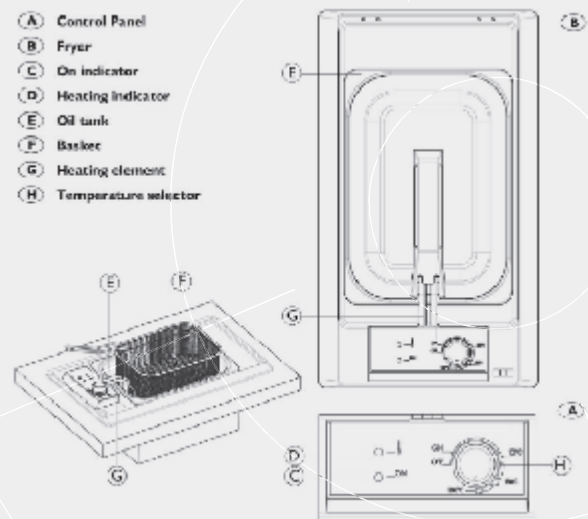

BUILT-IN DISHWASHERS



Dishwasher

BUILT-IN DISHWASHERS



FDW BI 6PR12S

Dimension

Product Dimension (L*W*H): 598*570*815 mm
 Package Dimension (L*W*H): 630*635*889 mm

Main Features

Capacity (place settings): 12
 Energy Consumption (KWH): 291
 Energy Efficiency: A+
 Noise Level: 49 dB(A)
 Delay Start: 1-24 hours
 Third Layer Cutlery Basket
 Half Load
 Height adjustable upper basket

Program

Nos. of program: 6-Intensive, Normal, Eco, 1 Hour
 Exprss, Glass, Rapid

Controls

Type of control: Electronic
 Push button functions: Program, Half Load, Delay Start
 and On/Off

Indicators

Functions of Display: Programs, Rinse Aid, Salt Half
 Load, Child Lock, Remaining Time, Error Codes and
 Delay Start

Technical & Internal Specification

Type of heating element: Hidden
 Power of heat element(230V): 1800W
 Filter type: Micro/Main/Flat
 Filter material: Plastic+stainless steel
 Tub material: SS 304&SS 430
 Color of basket(white/grey): Grey
 Spray arms: Upper & Lower
 Water softener: Electronic Adjustable
 Drying system: Natural Drying
 Inlet hose length: 1500mm
 Outlet hose length: 1500mm
 Connected load: 1760/1930/2100W
 Voltage: 220/230/240 V
 Frequency: 50/60 Hz

BUILT-IN DISHWASHERS



FDW BI 8PR14S

Dimension:

Product Dimension (L*W*H): 598*570*815 mm
 Package Dimension (L*W*H): 630*652*889 mm

Main Features

Capacity (place settings): 14
 Energy Consumption (KWH): 266
 Energy Efficiency: A++
 Cleaning Efficiency: A
 Drying Efficiency: A
 Noise Level: 49 dB(A)
 Delay Start: 1-24 hours
 Third Layer Cutlery Basket
 Height adjustable upper basket
 Dual zone Wash (Alternative Wash)

Program:

Nos. of program: 6- Intensive, Normal, Eco, 1 Hour Express, Soak, Auto

Controls:

Type of control: Electronic
 Push button functions: Program, Alternative Wash, Start/Pause, Delay Start and On/Off

Indicators:

Functions of Display: Programs, Rinse aid, Salt, Alternative Wash and Delay Start

Technical & Internal Specification:

Type of heating element: Hidden
 Power of heat element(230V): 1800W
 Filter type: Micro/Main/Flat
 Filter material: Plastic+ stainless steel
 Tub material: SS 304&SS 430
 Color of basket(white/grey): Grey
 Spray arms: Upper & Lower
 Water softener: Electronic Adjustable
 Drying system: Natural Drying
 Inlet hose length: 1500mm
 Outlet hose length: 1500mm
 Connected load: 1760/1930/2100 W
 Voltage: 220/230/240 V
 Frequency: 50/60 Hz



FDW BI 8 PR 14S HE

Dimensions:

Product Dimensions (L*W*H): 598 * 548 * 820 mm
 Packing Dimensions (L*W*H): 644 * 661 * 859 mm

Main features:

Finish: Fingerprint free SS
 Capacity (Place setting): 14
 Half Load
 Delay Start
 Energy Consumption: 0.95KBH
 Energy Efficiency: A+
 Cleaning Efficiency: A
 Drying Efficiency: A
 Noise Level: 44 dB(A)
 Delay Start
 Third Layer Cutlery Basket
 Height Adjustable Upper Basket
 Dual Zone Wash

Program:

No. of Program: 8--Pre-Wash, Mini 30, Delicate 40, Eco 50, Quick & Clean, Intensive 70, Baby Protect, Auto 40-85

Controls :

Type of Control: Electronic
 Program Control: Push Button
 LED follower on Door

Indicators:

Rinse Add indicator and Salt Indicator

Technical & Internal Specifications:

Type of Heating Element: Hidden
 Power of Heating Element: 1800 watt
 Filter Type: Micro, Main and Flat
 Filter Material: Metal
 Tub Material: SS 304
 Color of Basket: Grey
 Spray Arm: 3 (upper , Lower & Top)
 Water Softener: Automatic 45 dH
 Drying System: Active Ventilation
 Inlet Hose Length: 1500 mm
 Outlet Hose Length: 1500 mm
 Connected Load: 1900 – 2200W
 Voltage: 220/230/240 V
 Frequency: 50-60 Hz

FREE STANDING DISHWASHERS



Dishwasher

FREE STANDING DISHWASHERS



FDW SA 8PR 14S

Dimension

Product Dimension (L*W*Hm): 598*600*845
 Package Dimension (L*W*Hm): 630*652*889

Main Features

Capacity (place settings): 14
 Energy Consumption (KWH): 266
 Energy Efficiency (En50242): A++
 Cleaning Efficiency: A
 Drying Efficiency: A
 Noise Level: 49dB(A)
 Delay Start: 1-24 hours
 Third Layer Cutlery Basket
 Height adjustable upper basket
 Child Lock
 Dual zone Wash (Alternative Wash)

Program

Nos. of program: 8
 Intensive
 Normal
 Eco
 1 Hour Express
 Glass
 Rapid
 Soak
 Auto

Controls

Type of control: Electronic
 Push button functions: Program, Start/Pause, Alternative Wash, Delay Start, Language and On/Off

Indicators

Functions of Display: Programs, Language, Rinse Aid, Salt, Child lock
 Alternative Wash, Remaining Time, Error codes and Delay Start

Technical & Internal Specification

Removable top
 Type of heating element: Hidden
 Power of heat element(230V): 1800W
 Filter type: Micro/Main/Flat
 Filter material: Plastic+stainless steel
 Tub material: SS 304&SS 430
 Color of basket(white/grey): Grey
 Spray arms: Upper & Lower
 Water softener: Electronic Adjustable
 Drying system: Natural Drying
 Type of inlet hose: Standard
 Inlet hose length: 1500mm
 Outlet hose length: 1500mm
 Approvals(TUV,EMC,etc.): CE/GS/EMC/RoHS/Reach/PAH
 Connected load: 1760/1930/2100 W
 Voltage: 220/230/240 V
 Frequency: 50/60 Hz



FDW SA 7PR12S

Dimension

Product Dimension (L*W*Hm): 598*600*845
 Package Dimension (L*W*Hm): 630*652*889

Main Features

Capacity (place settings): 12
 Energy Consumption (KWH): 291
 Energy Efficiency (En50242): A+
 Noise Level: 49dB(A)
 Delay Start: 1-24 hours
 Third Layer Cutlery Basket
 Half Load: Yes
 Height adjustable upper basket: Yes
 Child Lock: Yes
 Dual zone Wash (Alternative Wash): No

Program

Nos. of program: 7
 Intensive
 Normal
 Eco
 1 Hour Express
 Glass
 Rapid
 Soak

Controls

Type of control: Electronic
 Push button functions: Program, Start/Pause, Half Load, Delay Start, On/Off and Child Lock

Indicators

Functions of Display: Programs, Rinse Aid, Salt Half Load, Child Lock
 Remaining Time, Error Codes and Delay Start

Technical & Internal Specification

Removable top
 Type of heating element: Hidden
 Power of heat element(230V): 1800W
 Filter type: Micro/Main/Flat
 Filter material: Plastic+stainless steel
 Tub material: SS 304&SS 430
 Color of basket(white/grey): Grey
 Spray arms: Upper & Lower
 Water softener: Electronic Adjustable
 Drying system: Natural Drying
 Type of inlet hose: Standard
 Inlet hose length: 1500mm
 Outlet hose length: 1500mm
 Approvals(TUV,EMC,etc.): CE/GS/EMC/RoHS/Reach/PAH
 Connected load: 1760/1930/2100 W
 Voltage : 220/230/240 V
 Frequency: 50/60 Hz

FREE STANDING DISHWASHERS



FDW SA 8PR14S HE

Dimensions

Product Dimensions (L*W*H mm): 598*571*850
Packing Dimensions (L*W*H mm): 644*6611 *889

Main Features

Capacity (place setting): 14
Energy Consumption: 0,95KWH
Energy Efficiency: A++
Cleaning Efficiency: A
Drying Efficiency: A
Noise Level: 43 db
Delay Start: 1/2-24h
Third Layer Basket
Height Adjustable Upper Rack

Program

Pre-wash
Mini 30
Eco 50
Quick&Clean
Intensive 70
Baby Protect
Active wash
Auto 40-65

Controls

Type of control: Electronic
Push Buttons

Indicators

Rinse aid
Salt aid

Technical & Internal Specifications

Type of Heating Element: Hidden
Power of Heat Element: 1800 WF
Litter Type: Micro/Main/Flat
Filter Material: Metal
Tub Material: SS 304
Color of Basket: Grey
Spray Arm: 3 (Upper / Lower / Top)
Water Softner: Automatic 45 dH
Drying System: Active Ventilation
Inlet Hose Length: 1500mm
Outlet Hose Length: 1500mm
Connected load: 1900-2200 W
Voltage: 220/230/240
Frequency :: 50/60 Hz

COOKING RANGES

Cooking Range



COOKING RANGES



FCR 43L 4B 4FB

General Specifications :

Oven Type: Gas
Cavity: 43 Liters
Finish: Black
Gas Grill
Grill Power 2Kw
Oven control Type: Two way valve
Double Glazed Oven Door
Flap Door Opening Type for Oven

Additional Features:

Push Button Ignition
Ignition for Burners
Ignition for Oven
Oven Light
Glass Top Cover
Enameled Interior for Easy cleaning
Adjustable Feet's
Flap Bottom Compartment

Hobs:

No. of Burners: 4

Burner Type:

Front Left Small: 1 Kw, Rear Left Medium : 2 Kw
Front Right Small: 2.9 Kw, Rear Right Medium : 2 Kw
Enameled Pan Support

Accessories :

Oven Tray: 1
Wire Shelf: 2
Heat Guard: 1

Electric Data :

Gas Type & Pressure: G28-30 Mbar - LPG
Voltage: 220-240 V
Frequency: 50 Hz
Current: 1A

Dimensions :

Product(L*W*H): 500*500*850mm
Weight: 43,8 Kg

COOKING RANGES



FCR 52L 4B BEG

General Specifications:

Oven Type: Gas
 Cavity: 52 Liters
 Finish: Stainless Steel
 Gas Grill
 Grill Power: 1800W
 Oven control Type : Two way valve
 Double Glazed Oven Door
 Flap Door Opening Type for Oven

Additional Features:

Auto Ignition
 Ignition for Burners
 Ignition for Oven
 FFD Device for Oven
 Thermostat
 Mechanical Timer
 Oven Light
 Glass Top Cover
 Enameled Interior for Easy cleaning
 Adjustable Feet's
 Flap Bottom Compartment

Hobs:

No. of Burners: 4
Burner Type :
 Front Left MTR: 2.5 Kw, Rear Left Medium: 1.75 Kw
 Front Right Large: 3 Kw, Rear Right Medium: 1.75 Kw
 Enameled Pan Support

Accessories :

1 Oven Tray, 1 Wire Shelf and 1 Heat Guard

Electric Data :

Gas Type & Pressure: G28-30 Mbar - LPG
 Voltage: 220-240 V, Frequency: 50 Hz, Current: 1A

Dimensions :

Product (L*W*H): 555*570*890 mm
 Weight: 44.5 kg



FCR 53L 4B HECIR

General Specifications:

Oven Type: Gas
 Cavity: 53 Liters
 Finish: Stainless Steel
 Gas Grill
 Grill Power: 1800W
 Oven control Type : Two way valve
 Double Glazed Oven Door
 Flap Door Opening Type for Oven

Additional Features :

Auto Ignition
 Ignition for Burners
 Ignition for Oven
 FFD Device for Oven
 Thermostat
 Digital Timer
 Oven Light
 Glass Top Cover
 Enameled Interior for Easy cleaning
 Adjustable Feet's
 Drawer Bottom Compartment
 Rotisseries

Hobs:

No. of Burners: 4
Burner Type:
 Front Left MTR : 2.5 Kw, Rear Left Medium : 1.75 Kw,
 Front Right T. Ring : 3.6 Kw, Rear Right Medium : 1.75 Kw
 Cast Iron Pan Support

Accessories:

1 Oven Tray, 1 Wire Shelf, 1 Heat Guard and 1 Additional Pan Support

Electric Data:

Gas Type & Pressure : G28-30 Mbar - LPG
 Voltage: 220-240 V, Frequency: 50 Hz, Current: 1A

Dimensions :

Product (L*W*H): 600*600*890 mm
 Weight: 48 kg

COOKING RANGES



FCR 53L 3B1H HECIR

General Specifications:

Oven Type: Electric
 Cavity: 53 Liters
 Finish: Stainless Steel
 Electric Grill
 Grill Power : 2kw
 Oven control Type: Rotary Switch
 Double Glazed Oven Door
 Flap Door Opening Type for Oven

Additional Features:

Auto Ignition
 Ignition for Burners
 Electric Hot Plate
 Thermostat
 Digital Timer
 Oven Light
 Glass Top Cover
 Enameled Interior for Easy cleaning
 Adjustable Feet's
 Drawer Bottom Compartment
 Turbo Fan

Hobs:

No. of Burners: 3 + 1 Hot Plate

Burner Type:

Front Left Large: 3 Kw, Rear Left Medium: 1.75 Kw
 Front Right T. Ring: 3.6 Kw, Rear Right Hot Plate: 1 Kw
 Cast Iron Pan Support

Accessories:

1 Oven Tray, 1Wire Shelf, 1Heat Guard and 1 Additional Pan Support

Electric Data:

Gas Type & Pressure: G28-30 Mbar - LPG
 Voltage: 220-240 V, Frequency: 50 Hz, Current: 1A

Dimensions:

Product(L*W*H) : 600*600*890 mm
 Weight: 48 kg.



FCR 114L 5B HECIR

General Specifications:

Oven Type : Gas
 Cavity: 114 Liters
 Finish: Stainless Steel
 Gas Grill
 Grill Power: 2300 W
 Oven control Type: Two Way Valve
 Double Glazed Oven Door
 Flap Door Opening Type for Oven

Additional Features:

Auto Ignition
 Ignition for Burners
 Ignition for Oven
 FFD Device for Oven
 Thermostat
 Digital Timer
 Oven Light
 Glass Top Cover
 Enameled Interior for Easy cleaning
 Adjustable Feet's
 Drawer Bottom Compartment
 Rotisseries

Hobs:

No. of Burners: 5

Burner Type:

Front Left Medium: 1.75 Kw, Rear Left Medium: 2 Kw
 Front Right MTR: 2.5 Kw, Rear Right Large: 3 Kw
 Center T. Ring: 3.6 Kw and Cast Iron Pan Support

Accessories:

1 Oven Tray, 1Wire Shelf, 1Heat Guard and 1 Additional Pan Support

Electric Data:

Gas Type & Pressure: G28-30 Mbar - LPG
 Voltage: 220-240 V, Frequency: 50 Hz, Current: 1A

Dimensions:

Product (L*W*H): 900*600*890 mm
 Weight: 70 kg.